

DUAL FLOW ROTARY JOINTS

Type SXB – Two ports, 180°

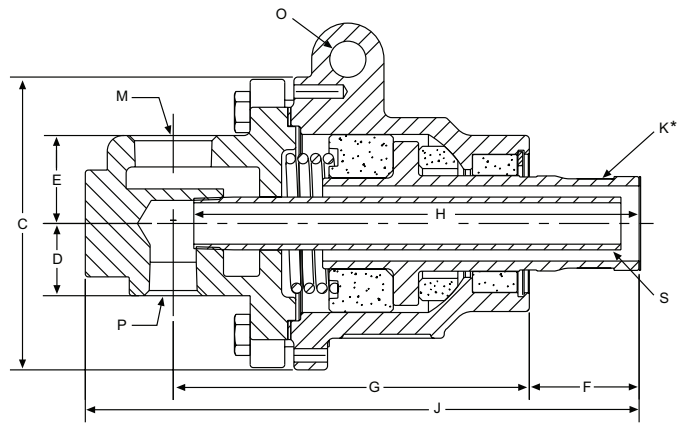

| Size (K)* | M | P | S | C | D | E | F | G | H | J | O | Units |
|-----------|-------------|-----------------|---------------|------|------|------|------|-------|-------|-------|------|--------|
| 3/4" | 1/2" | 1/2" | 1/8" - 1/4" | 3.69 | 0.75 | 1.31 | 2.00 | 4.56 | 6.00 | 7.88 | 0.42 | inches |
| | | | | 94 | 19 | 33 | 51 | 116 | 152 | 200 | 11 | mm |
| 1" | 3/4" | 1/2" | 1/4" - 3/8" | 4.12 | 1.12 | 1.38 | 1.81 | 5.00 | 6.75 | 8.94 | 0.44 | inches |
| | | | | 105 | 28 | 35 | 46 | 127 | 171 | 227 | 11 | mm |
| 1 1/4" | 1" | 1/2" | 3/8" - 1/2" | 5.25 | 1.38 | 1.81 | 2.00 | 6.50 | 7.75 | 10.44 | 0.56 | inches |
| | | | | 133 | 35 | 46 | 51 | 165 | 197 | 265 | 14 | mm |
| 1 1/2" | 1 1/4" | 3/4" | 1/2" - 3/4" | 6.56 | 1.44 | 1.75 | 2.19 | 7.12 | 8.88 | 11.00 | 0.72 | inches |
| | | | | 167 | 37 | 44 | 56 | 181 | 226 | 279 | 18 | mm |
| 2" | 1 1/2" | 3/4" | 1/2" - 3/4" | 6.94 | 1.50 | 1.88 | 2.25 | 7.75 | 9.50 | 12.28 | 0.88 | inches |
| | | | | 176 | 38 | 48 | 57 | 197 | 241 | 312 | 22 | mm |
| 2 1/2" | 2" | 1" | 3/4" - 1" | 7.81 | 1.50 | 2.06 | 2.62 | 8.25 | 10.30 | 13.60 | 0.88 | inches |
| | | | | 198 | 38 | 52 | 67 | 210 | 262 | 345 | 22 | mm |
| 3" | 2" - 2 1/2" | 1 1/4" - 1 1/2" | 3/4" - 1 1/2" | 8.62 | 2.88 | 3.56 | 3.00 | 10.44 | 12.00 | 16.64 | 1.09 | inches |
| | | | | 219 | 73 | 90 | 76 | 265 | 305 | 423 | 28 | mm |

* Available threaded (NPT, BSPT, BSP) or "Q" Quick Release Nipple

| | Steam/Water | Hot Oil |
|----------------|-------------------|-------------------|
| Std. Pressure: | 300 psig (20 bar) | 150 psig (10 bar) |
| High Pressure: | 510 psig (35 bar) | 150 psig (10 bar) |
| Temperature: | 550°F (288°C) | 650°F (343°C) |
| Speed: | Up to 550 RPM | Up to 550 RPM |

See page 11 for PV curves and maximum speed ratings